

Solar Road Stud AL-103

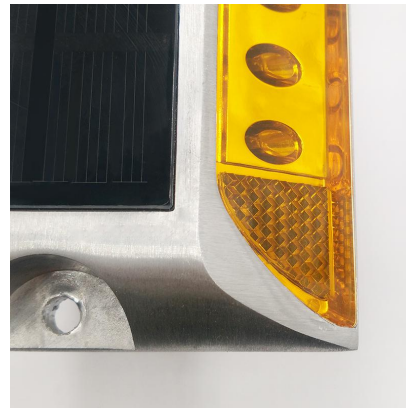

The solar road studs can help to reduce accident at regional rail crossing, intersection and provide guidance and hazard warning to drivers in darkness and bad weathers. The solar system of aluminum road stud is conducive for reducing environmental impact and saving costs. With more than 15 years of factory experience, cat eye road stud produced by our company owns competitive aluminum road stud price and offers more choice to global traffic road safety market and trustworthy partners all over the world.

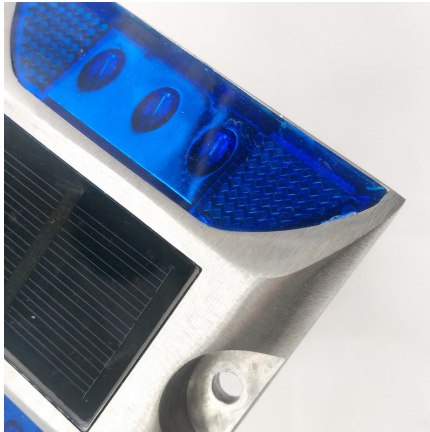

Solar Road stud solutions

Ip68 design for reflector

**Can work more than
3 years normally**



Larger solar charging area

Anti-impact

**Easy installation
no maintenance**

Solar road stud provides a sustainable solution with innovative solar power. The intelligent aluminum solar road stud can help to reduce accident at regional rail crossing, intersection and provide guidance and hazard warning to drivers in darkness and bad weathers.

Product Name	solar road stud
Body material	PC & Dia-cast aluminum alloy
Power supply	Monocrystalline solar panel 2.5V/120MA for NI-MH; 5V/60MA for lithum battery;
Storage Battery	NI-MH Battery Or Capacitor
LED	2PCS LED (available with Blue, Green, Red, Yellow or White)
working mode	Recharging at day and working automatically at night
Working hours	(1).Blinking:120hours for NI-MH battery; 120hours for lithum battery. (2).Constant:40hours for NI-MH battery; 35hours for lithum battery.
Life span	2years for NI-MH battery; 5years for Lithum battery;
Visual distance	>800m
Water proof	IP68
Resistance	>20T
Size	103X103X23mm
Packing	2pc/box;60pcs/ctn
Carton size	58.5*24.5*18.5cm
Weight	21kgs/ctn
View Distance:	Over 800m

Long working-time. 180 hours for flashing, 40 hours for steady in fog or rainy days after fully charged. Designed by integrated circuit and thermostability rechargeable batteries from solar road studs manufacturers. Ensure the long servicing life and performance of the product.

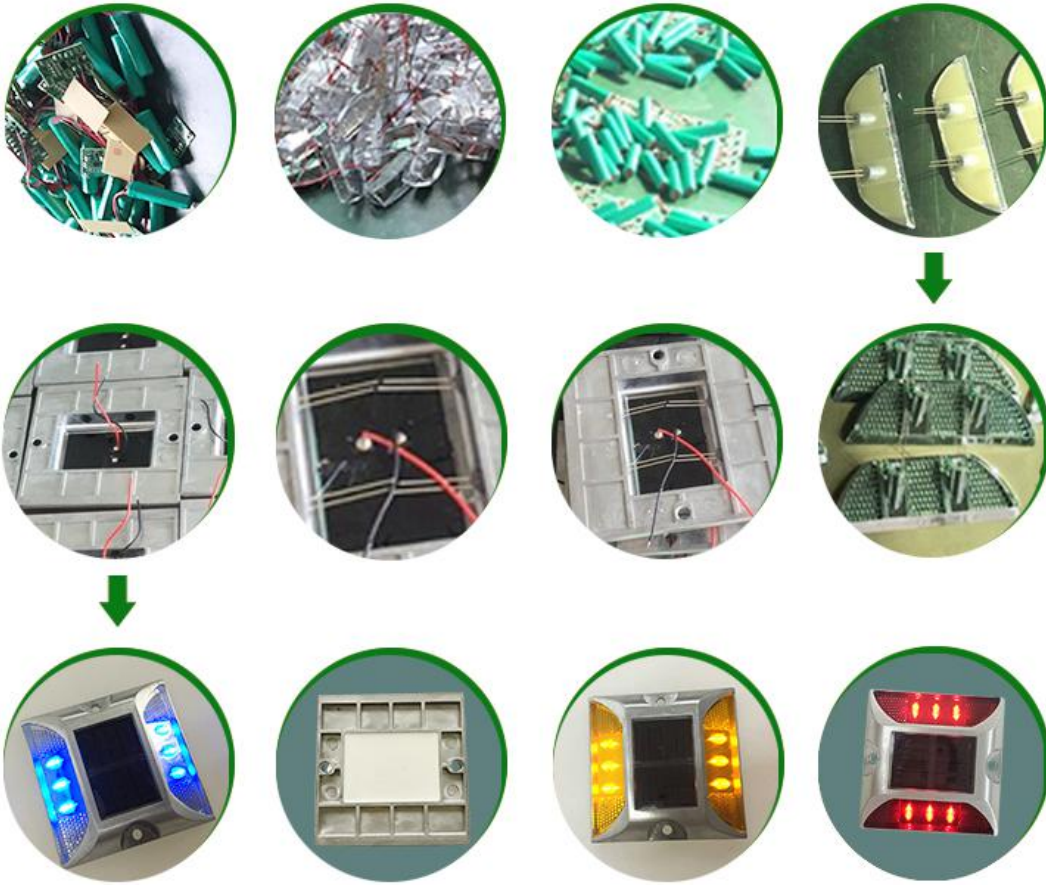

Applications:



Solar Brick Light

AL-1010

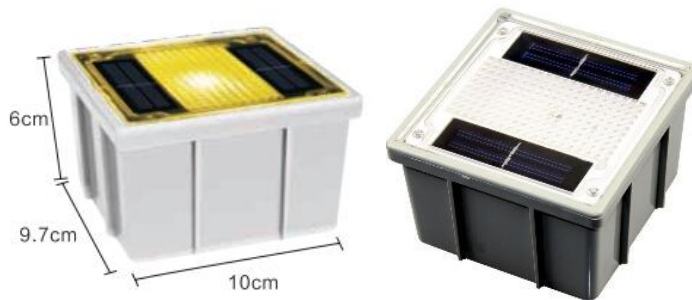

Features and Configuration:

1. Solar Panel: polycrystalline silicon, 2V/50MA
2. Storage Battery: 1 x 500mAh AAA 1.2V Ni-Mh
3. Light Source: 1 x 0.07W amber color led ($\Phi 5 \times 8.7\text{mm}$ /round)
4. Color Temperature: 6000K Lumen: 7 LM
5. Working Time: 8-10h Charging Time: 4.5H
6. IP: 68 waterproof.
7. Main Material: plastic, AB+PS
8. Item Size: 10*10*6CM
9. crush color: grey
10. Function: auto light at night and auto charge in the daytime, Waterproof IP68
11. Package: Box size: 10.5*10.5*6.5cm / 0.29KGS
Carton size: 30* 23*23CM/ 4.6kgs 16pcs/CTN
12. Applications: Driveway, Pavement, garden, etc



Solar Brick Light

AL-1910



Auto light at night and auto charge in the daytime, Waterproof IP68

1. Solar Panel: polycrystalline silicon, 2*1V/50MA
 2. Storage Battery: 1 x 500mAh AAA 1.2V Ni-Mh
 3. Light Source: 2 x 0.07W ($\Phi 5*8.7\text{mm}/\text{round}$)
 4. Color Temperature: 6000-7000K Lumen: 7 LM
 5. Working Time: 8-10h
- Charging Time: 4.5H
6. IP: 68 waterproof .
 7. Main Material: plastic, AB+PS
 8. Item Size: 19.5*10*6CM
 9. crush color: grey



solar underground light

Energy-saving, Environment friendly



Underground Light 100R-1

- No UV or IR in the spectrum
- Energy-saving, Environment friendly, and only 20% power consumption of halogen lamp and incandescent lamp.
- Aluminum-alloy lamp housing for superior heat dissipation.
- Particularly designed constant current driver for open or short circuit protection
- super power capacity, Longer life (More than 10 years)
- Working model: Recharging at day and working automatically
- Working period: Full recharging for 8 hours and working in 120 hours constantly.



Five Colors For Choose



Red

Yellow

White

Blue

Green

Specification

Solar Panel	Monocrystalline 2.5V/180MA
Battery	NI-MH
Body material	Metal shell&Tempered Glass
LED Color	White Green Red Yellow Blue
Size	Dia100*67mm
Led Quantity	Ultra bright LED 4pcs
Waterproof	IP68
Load capacity	3T

Application



- Replacement bulbs for traditional halogen lamps, especially for museums, art galleries, cosmetic, where UV or IR radiation is undesirable.
- Suitable for products range of hotel, bar, SPA, hardware store, lighting store, exhibition booth, supermarket, electronic store, show room, and internet shop.

Solar Underground Light AL-2010



Solar cell	Polycrystalline silicon/Monocrystalline silicon
light source	super luminosity LED
Luminous mode	Constant Type
Work time	more than 30 hours for Constant Type(full charge constant ON)
Work temperature	-40°C ~ 65°C
Light material	Aluminum alloy ,Polycarbonate and stainless steel
Resist compression	20 tons
Waterproof grade	IP > 67
Life	> 5 years(Ni-MH) or > 15years (Super Capacitor)
View distance	over 800m
Warranty	14 months
Installation remarks	gum fix
No.ctns	20PCS
Packing Meas(CM)	42x28.5x22
N.W (KG)	15.6
G.W (KG)	16.6
Color	red, yellow, blue, green, white



Solar Underground Light ZH-01

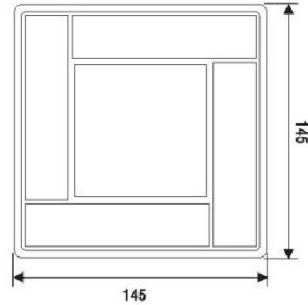

Solar panel:0.5w 2.5V/200mA polycrystalline

Work mode:constant lighting/glitter lighting/color changes

LED Quantity:6pcs or according to ur request.

LED color:Red/Yellow/Blue/Green/White/

Material:PC

Battery:1800mAh Ni-Mh battery or LiFePO4 battery.

Working Temperature:-25°C to 70°C

Waterproof:IP68

Size:145*145*40mm

Weight:605g

Solar Underground Light ZH-145

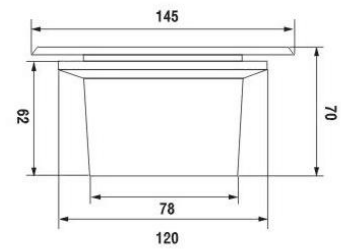
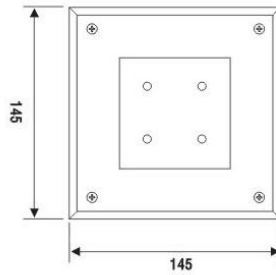
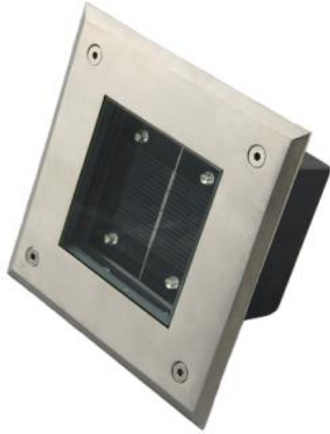

Solar panel:0.6w

LED Quantity:4pcs

LED color:Red/Yellow/Blue/Green/White

Material:Stainless steel&Aluminum alloy

Battery:Ni-Mh,1800mAh

Working time: 8-10 hours by shined for 8 hours with standard luminous intensity

Waterproof:IP67

Application:Plaza,Park,Garden,Street,Walkway,etc.

Size:145*145*70mm

Carton size:480*360*340mm

Quantity/Carton:18pcs

G. W/N.W:20/19kg

Solar Underground Light ZH-12

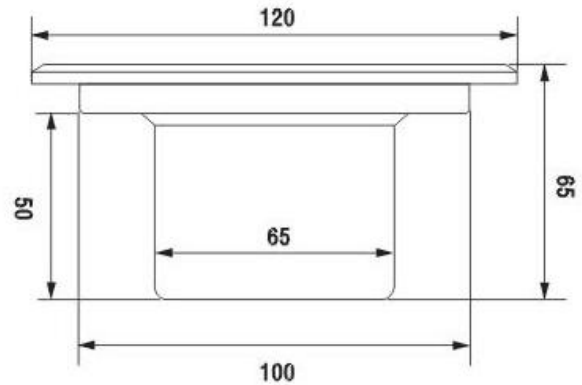
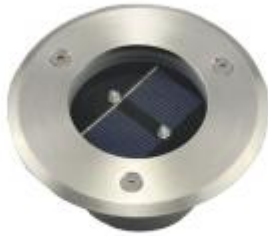

Solar panel:0.4w

LED Quantity:2pcs

LED color:Red/Yellow/Blue/Green/White

Material:Stainless steel&Aluminum alloy

Battery:Ni-Mh,750mAh

Working time: 8-10 hours by shined for 8 hours with standard luminous intensity

Surface Load Capacity:1000kg

Waterproof:IP68

Application:Plaza,Park,Garden,Street,Walkway,etc.

Size:Dia.120*65mm

Carton size:680*290*230mm

Quantity/Carton:30pcs

G.W/N.W:14/13kg